

2421 Fourth Street
Berkeley, California 94710
510.649.1414
www.TrachtenbergArch.com



**1201
SAN PABLO
MIXED-USE**

Berkeley, CA 94706

- 03.11.2021 SB-330 PRE-APPLICATION
- 04.29.2021 ZONING APPLICATION
- 07.13.2021 ZONING COMPLETENESS

ALL DRAWINGS AND WRITTEN MATERIAL APPEARING
HEREIN CONSTITUTE ORIGINAL AND UNPUBLISHED
WORK OF THE ARCHITECT AND MAY NOT BE
DUPLICATED, USED OR DISCLOSED WITHOUT WRITTEN
CONSENT OF TRACHTENBERG ARCHITECTS.

JOB: 1928

SHEET:
**BUILDING
ELEVATIONS**

A3.4



CAST IN PLACE CONCRETE

1 SOUTH ELEVATION
3/32" = 1'-0" @ 11X17 3/16" = 1'-0" @ 24X36 0 4 8 16

2421 Fourth Street
Berkeley, California 94710
510.649.1414
www.TrachtenbergArch.com



**1201
SAN PABLO
MIXED-USE**

Berkeley, CA 94706

- 03.11.2021 SB-330 PRE-APPLICATION
- 04.29.2021 ZONING APPLICATION
- 07.13.2021 ZONING COMPLETENESS

ALL DRAWINGS AND WRITTEN MATERIAL APPEARING HEREIN CONSTITUTE ORIGINAL AND UNPUBLISHED WORK OF THE ARCHITECT AND MAY NOT BE DUPLICATED, USED OR DISCLOSED WITHOUT WRITTEN CONSENT OF TRACHTENBERG ARCHITECTS.

JOB: 1928

SHEET:

STREET STRIP ELEVATIONS

A3.5



2

STREET STRIP ELEVATION @ HARRISON ST.

1/32" = 1'-0" @ 11X17 1/16" = 1'-0" @ 24X36

0 4 8 16 32



1

STREET STRIP ELEVATION @ SAN PABLO AVE.

1/32" = 1'-0" @ 11X17 1/16" = 1'-0" @ 24X36

0 4 8 16 32

2421 Fourth Street
Berkeley, California 94710
510.649.1414
www.TrachtenbergArch.com



**1201
SAN PABLO
MIXED-USE**

Berkeley, CA 94706

- 03.11.2021 SB-330 PRE-APPLICATION
- 04.29.2021 ZONING APPLICATION
- 07.13.2021 ZONING COMPLETENESS

ALL DRAWINGS AND WRITTEN MATERIAL APPEARING
HEREIN CONSTITUTE ORIGINAL AND UNPUBLISHED
WORK OF THE ARCHITECT AND MAY NOT BE
DUPLICATED, USED OR DISCLOSED WITHOUT WRITTEN
CONSENT OF TRACHTENBERG ARCHITECTS.

JOB: 1928

SHEET:

PERSPECTIVE
VIEWS

A3.6

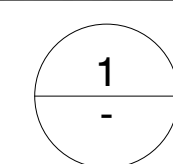

VIEW ALONG SAN PABLO - LOOKING SOUTH



**1201
SAN PABLO
MIXED-USE**

Berkeley, CA 94706

03.11.2021 SB-330 PRE-APPLICATION
04.29.2021 ZONING APPLICATION
07.13.2021 ZONING COMPLETENESS

ALL DRAWINGS AND WRITTEN MATERIAL APPEARING
HEREIN CONSTITUTE ORIGINAL AND UNPUBLISHED
WORK OF THE ARCHITECT AND MAY NOT BE
DUPLICATED, USED OR DISCLOSED WITHOUT WRITTEN
CONSENT OF TRACHTENBERG ARCHITECTS.

JOB: 1928

SHEET:

PERSPECTIVE
VIEWS

A3.7

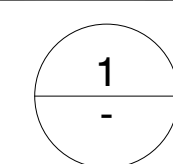

VIEW ALONG SAN PABLO - LOOKING NORTH



**1201
SAN PABLO
MIXED-USE**

Berkeley, CA 94706

03.11.2021 SB-330 PRE-APPLICATION
04.29.2021 ZONING APPLICATION
07.13.2021 ZONING COMPLETENESS

ALL DRAWINGS AND WRITTEN MATERIAL APPEARING
HEREIN CONSTITUTE ORIGINAL AND UNPUBLISHED
WORK OF THE ARCHITECT AND MAY NOT BE
DUPLICATED, USED OR DISCLOSED WITHOUT WRITTEN
CONSENT OF TRACHTENBERG ARCHITECTS.

JOB: 1928

SHEET:

PERSPECTIVE
VIEWS

A3.8

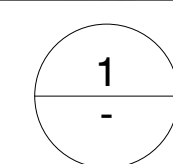

VIEW ALONG HARRISON - LOOKING EAST

2421 Fourth Street
Berkeley, California 94710
510.649.1414
www.TrachtenbergArch.com



**1201
SAN PABLO
MIXED-USE**

Berkeley, CA 94706

03.11.2021 SB-330 PRE-APPLICATION
04.29.2021 ZONING APPLICATION
07.13.2021 ZONING COMPLETENESS

ALL DRAWINGS AND WRITTEN MATERIAL APPEARING
HEREIN CONSTITUTE ORIGINAL AND UNPUBLISHED
WORK OF THE ARCHITECT AND MAY NOT BE
DUPLICATED, USED OR DISCLOSED WITHOUT WRITTEN
CONSENT OF TRACHTENBERG ARCHITECTS.

JOB: 1928

SHEET:

PERSPECTIVE
VIEWS

A3.9

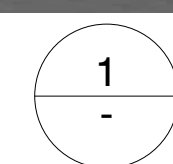

VIEW ALONG HARRISON - LOOKING WEST



4 HARRISON LOOKING EAST - AFTER



2 SAN PABLO LOOKING SOUTH - AFTER



3 HARRISON LOOKING EAST - BEFORE



1 SAN PABLO LOOKING SOUTH - BEFORE



1201
SAN PABLO
MIXED-USE

Berkeley, CA 94706

- 03.11.2021 SB-330 PRE-APPLICATION
- 04.29.2021 ZONING APPLICATION
- 07.13.2021 ZONING COMPLETENESS

ALL DRAWINGS AND WRITTEN MATERIAL APPEARING HEREIN CONSTITUTE ORIGINAL AND UNPUBLISHED WORK OF THE ARCHITECT AND MAY NOT BE DUPLICATED, USED OR DISCLOSED WITHOUT WRITTEN CONSENT OF TRACHTENBERG ARCHITECTS.

JOB: 1928

SHEET:
PHOTO MATCH
PERSPECTIVES

2421 Fourth Street
Berkeley, California 94710
510.649.1414
www.TrachtenbergArch.com



**1201
SAN PABLO
MIXED-USE**

Berkeley, CA 94706

03.11.2021 SB-330 PRE-APPLICATION
04.29.2021 ZONING APPLICATION
07.13.2021 ZONING COMPLETENESS

ALL DRAWINGS AND WRITTEN MATERIAL APPEARING
HEREIN CONSTITUTE ORIGINAL AND UNPUBLISHED
WORK OF THE ARCHITECT AND MAY NOT BE
DUPLICATED, USED OR DISCLOSED WITHOUT WRITTEN
CONSENT OF TRACHTENBERG ARCHITECTS.

JOB: 1928

SHEET:

BUILDING SECTION

A4.1

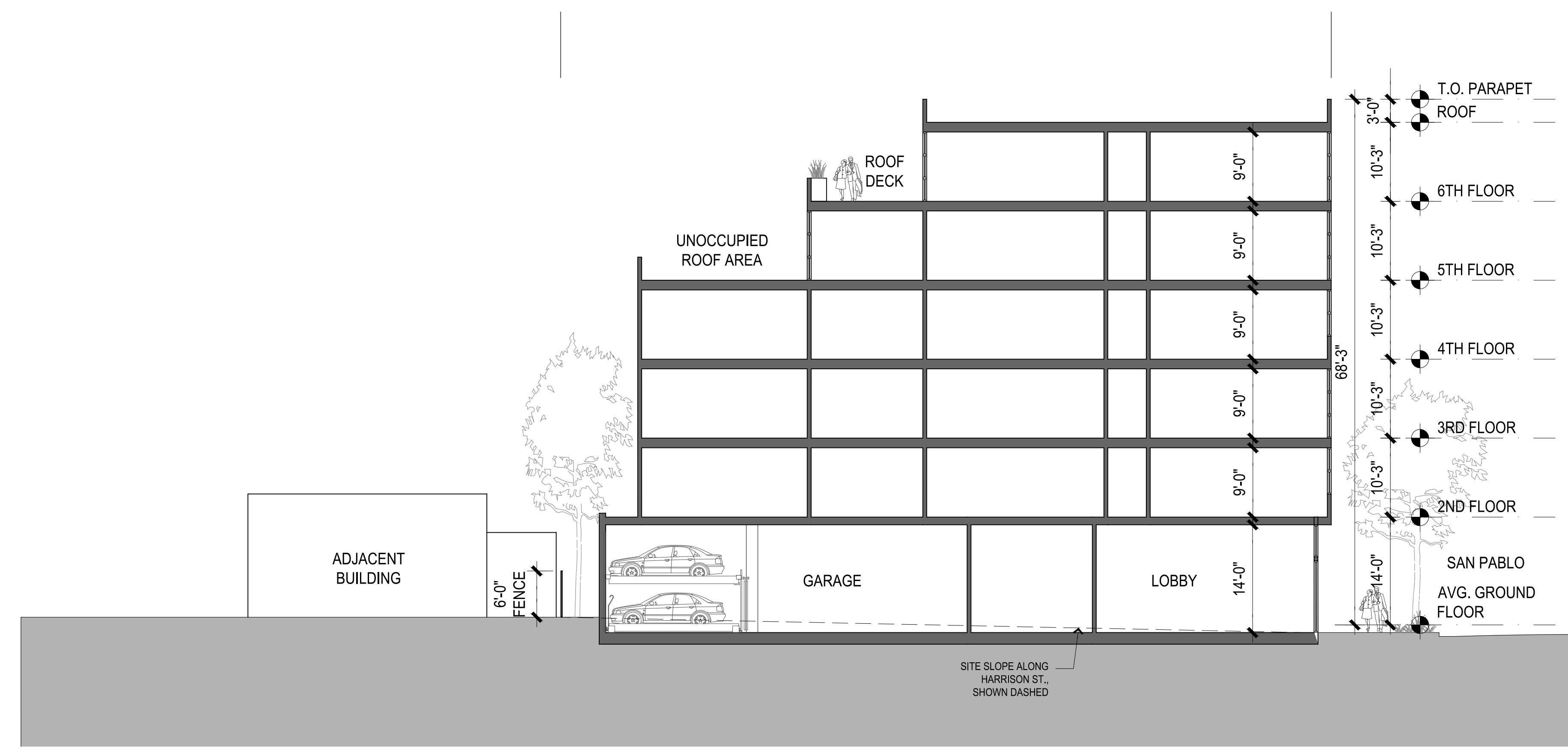

2 E-W SECTION THROUGH PODIUM GARDEN
3/64"=1'-0" @ 11X17 3/32"=1'-0" @ 24X36
0 2 4 8 16

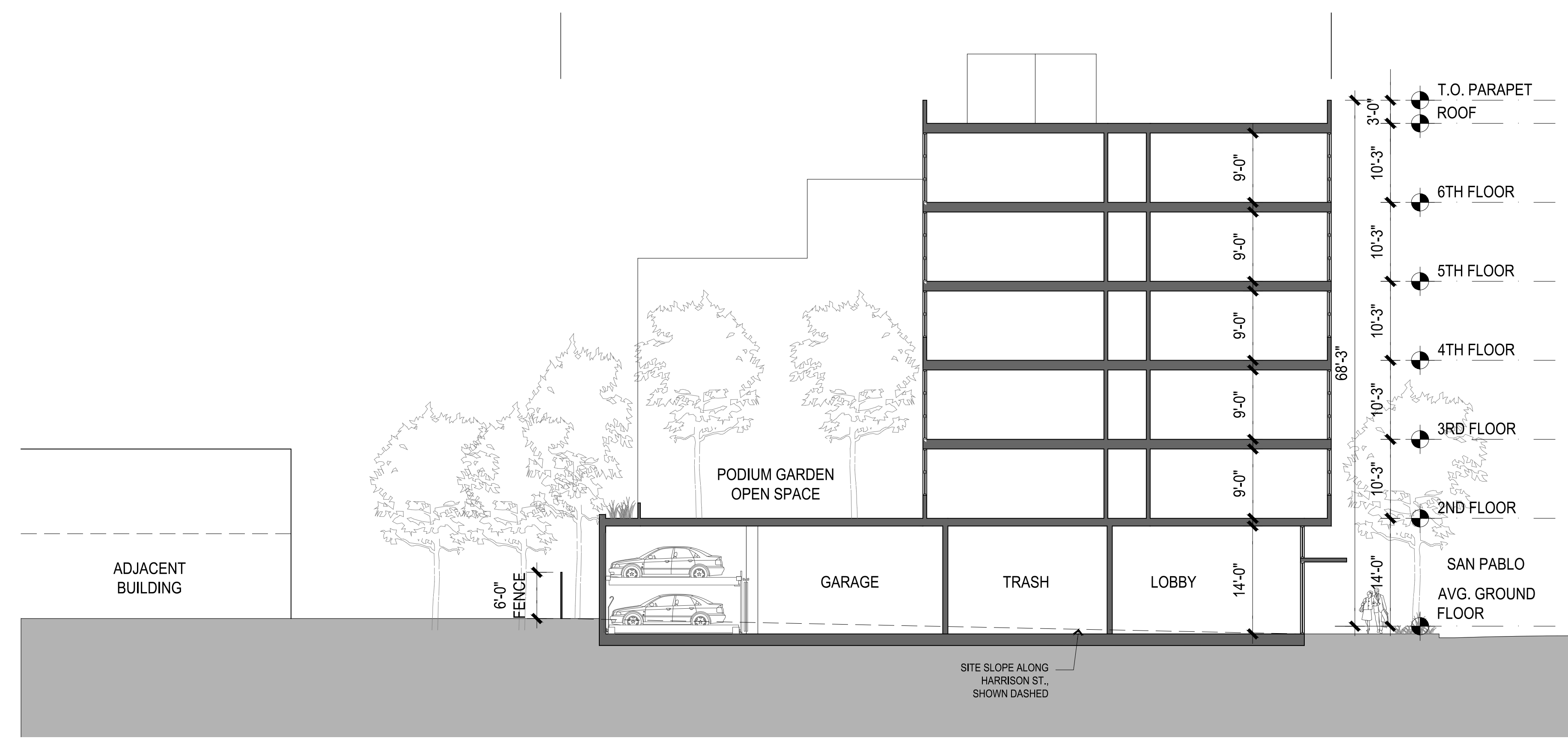

1 E-W SECTION
3/64"=1'-0" @ 11X17 3/32"=1'-0" @ 24X36
0 2 4 8 16

2421 Fourth Street
Berkeley, California 94710
510.649.1414
www.TrachtenbergArch.com



**1201
SAN PABLO
MIXED-USE**

Berkeley, CA 94706

03.11.2021 SB-330 PRE-APPLICATION
04.29.2021 ZONING APPLICATION
07.13.2021 ZONING COMPLETENESS

ALL DRAWINGS AND WRITTEN MATERIAL APPEARING HEREIN CONSTITUTE ORIGINAL AND UNPUBLISHED WORK OF THE ARCHITECT AND MAY NOT BE DUPLICATED, USED OR DISCLOSED WITHOUT WRITTEN CONSENT OF TRACHTENBERG ARCHITECTS.

JOB: 1928

SHEET:

WALL SECTIONS & DETAILS

A4.2

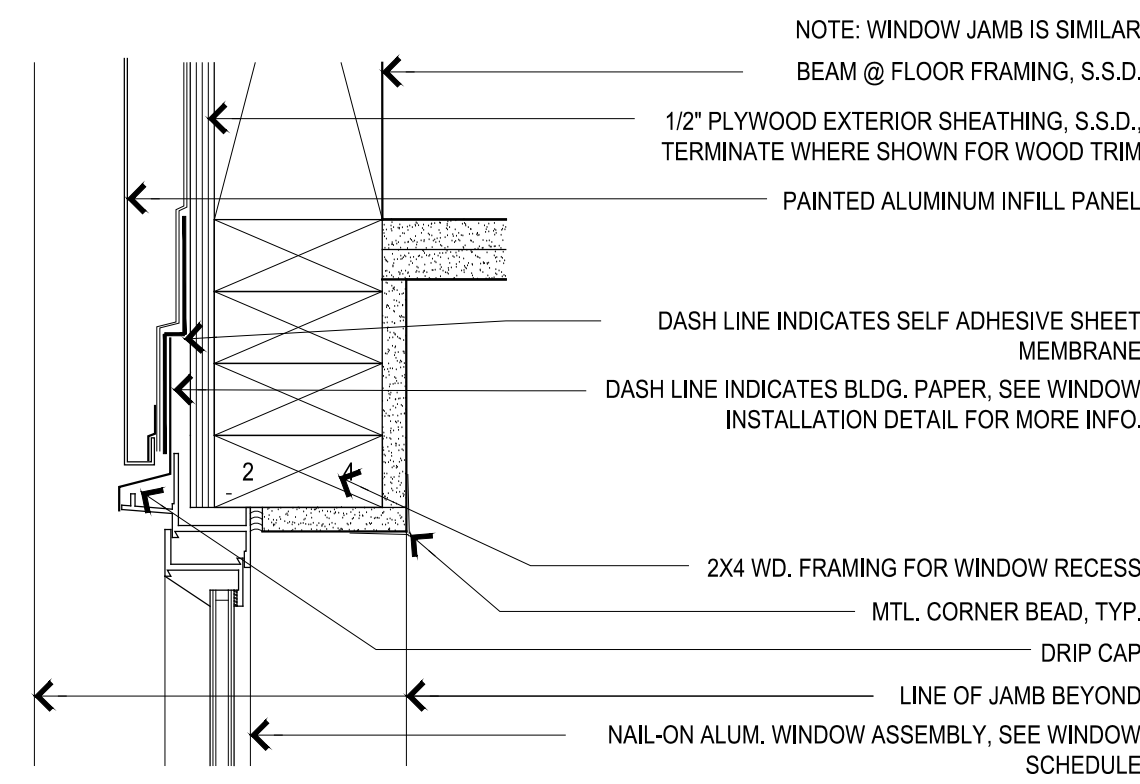

8 HEAD @ FILL PANEL
3"=1'-0"

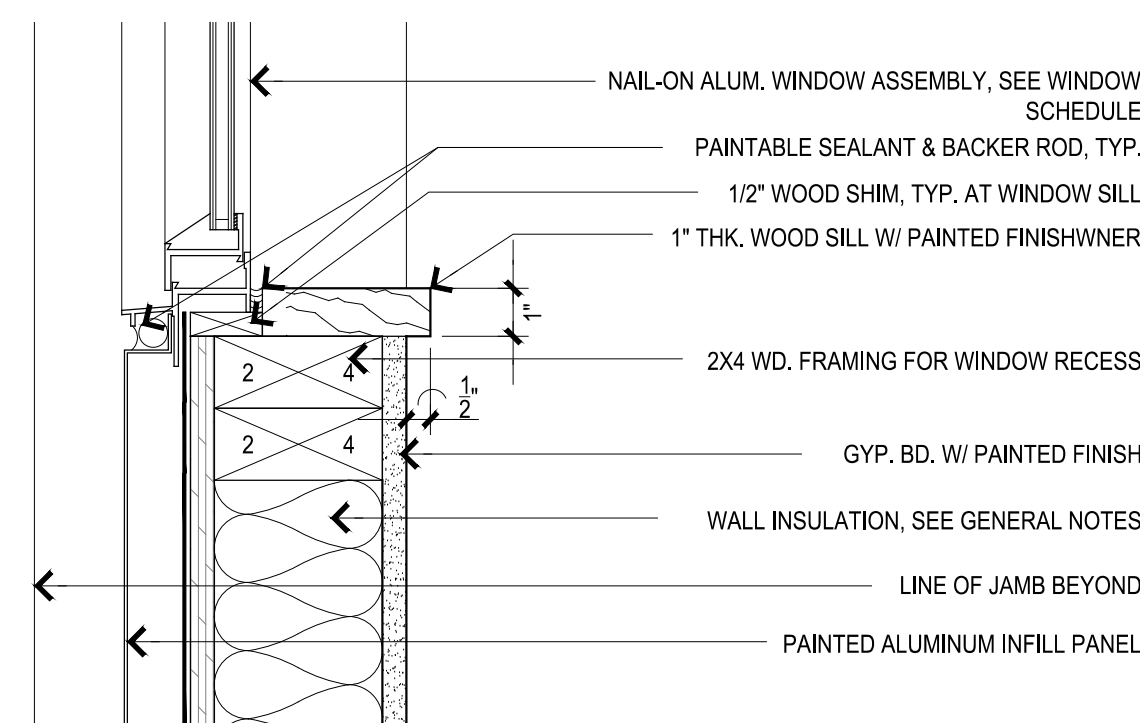

7 SILL AT FILL PANEL
3"=1'-0"

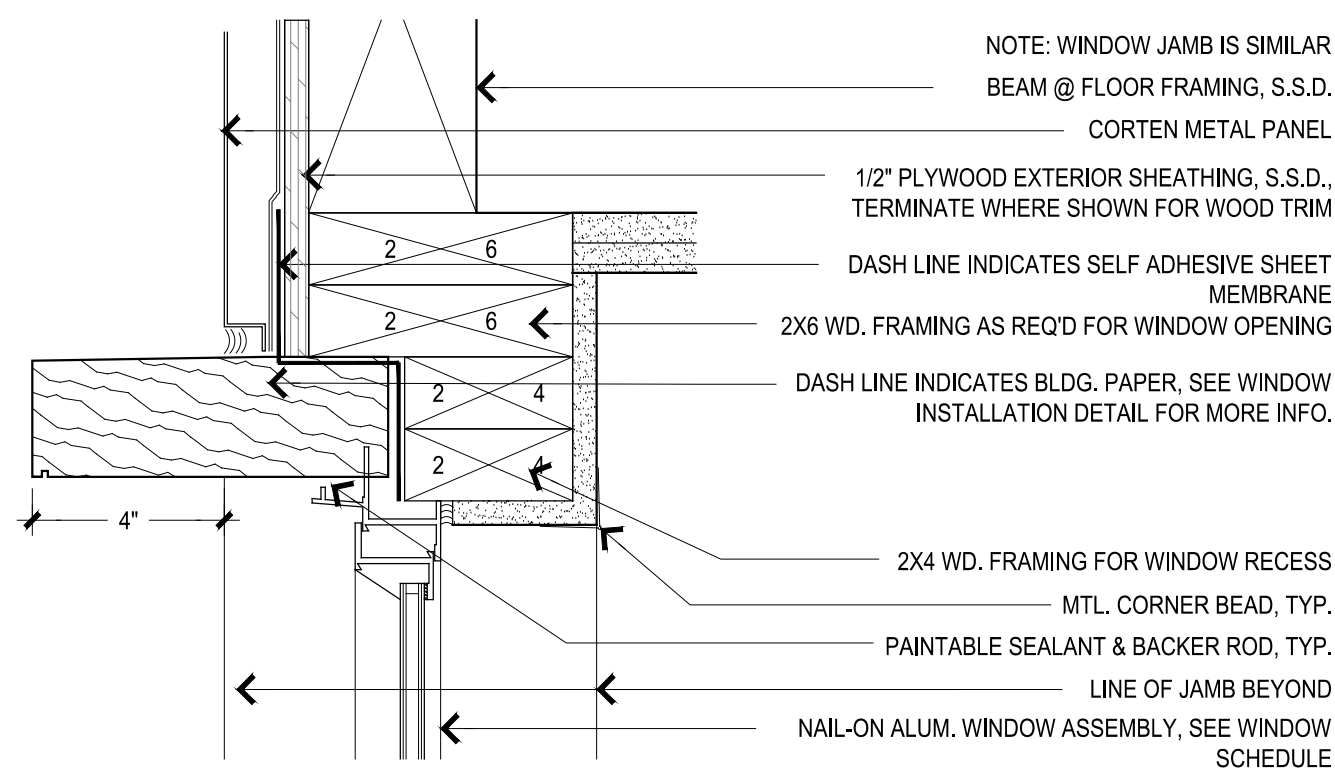

10 TYP. HEAD @ CORTEN
3"=1'-0"

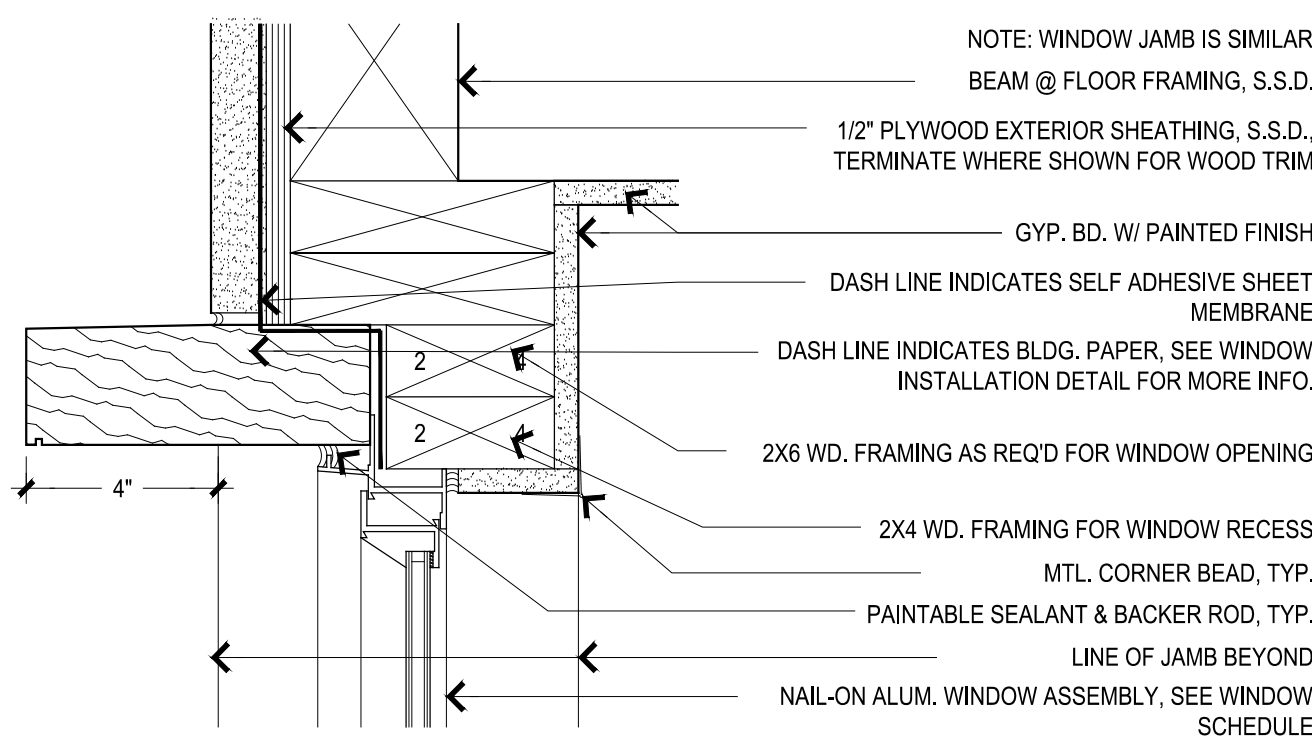

6 TYP. STUCCO HEAD / JAMB
3"=1'-0"

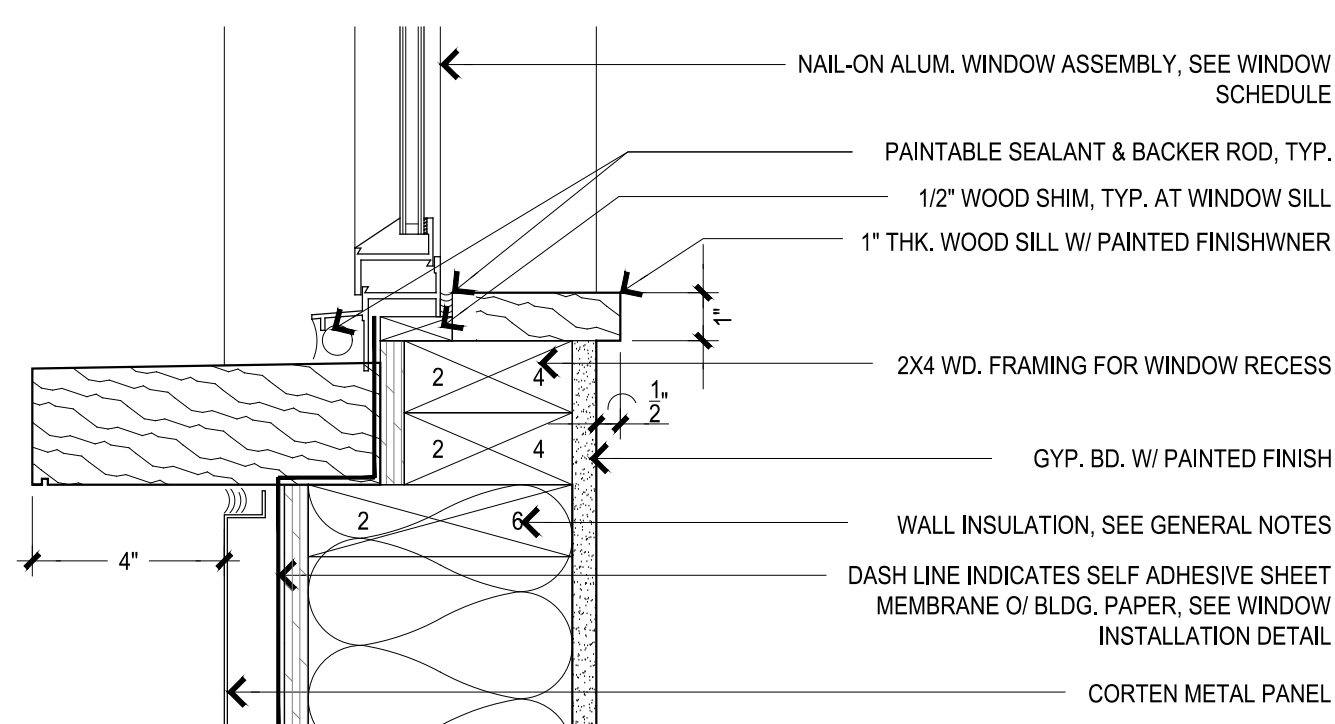

9 TYP. SILL @ CORTEN
3"=1'-0"

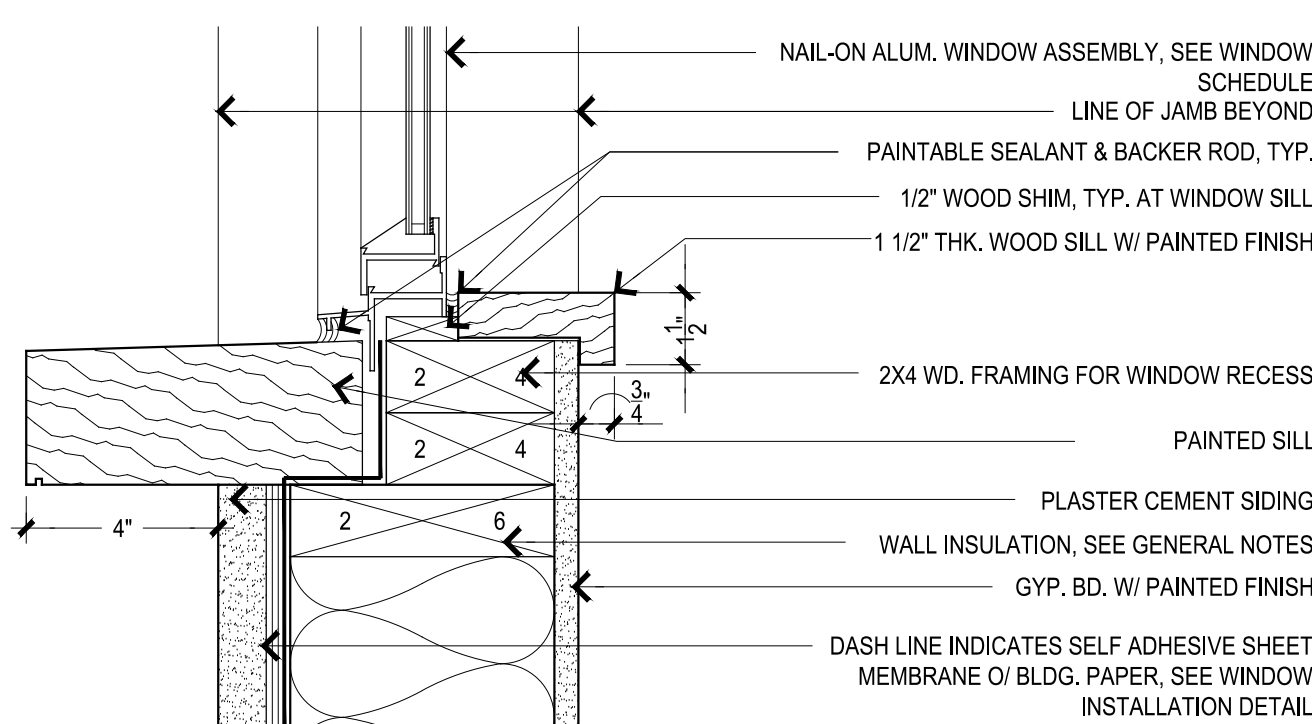

5 TYP. STUCCO SILL
3"=1'-0"

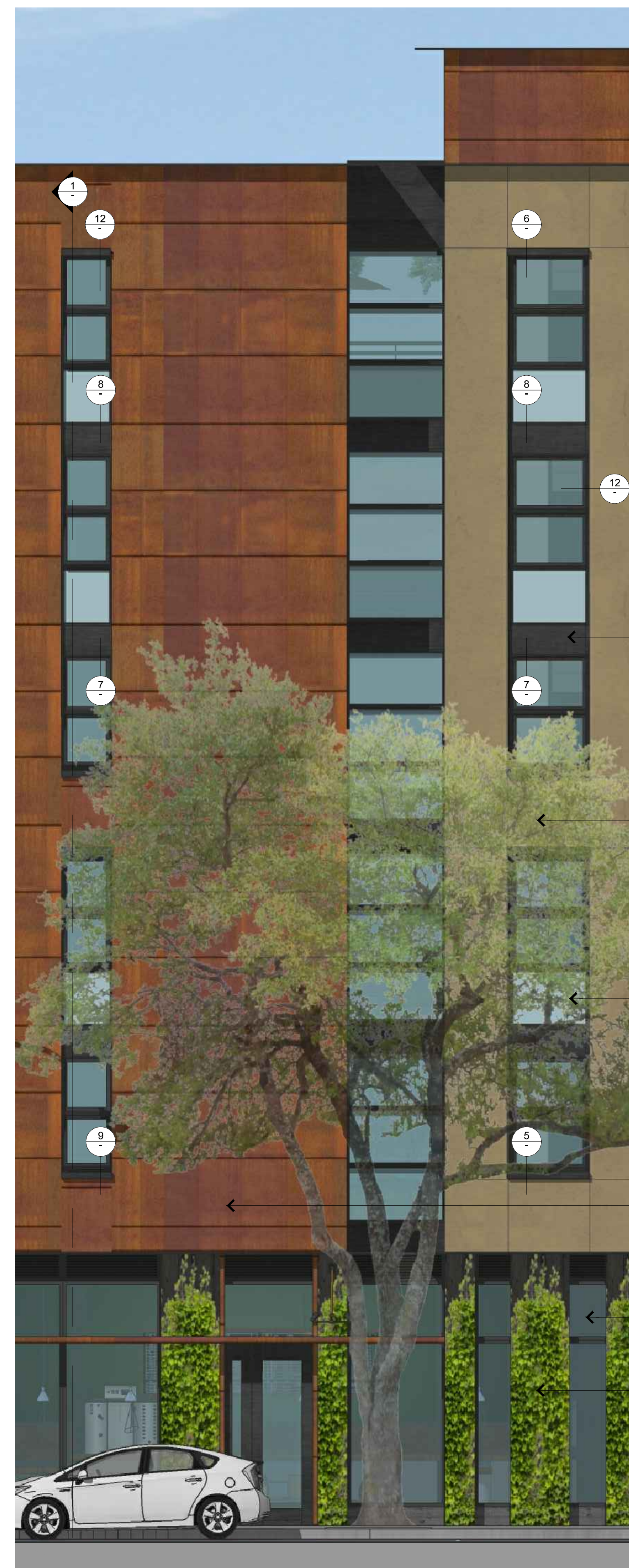

2 ELEVATION DETAIL
1/8"=1'-0" @ 11X17 1/4"=1'-0" @ 24X36

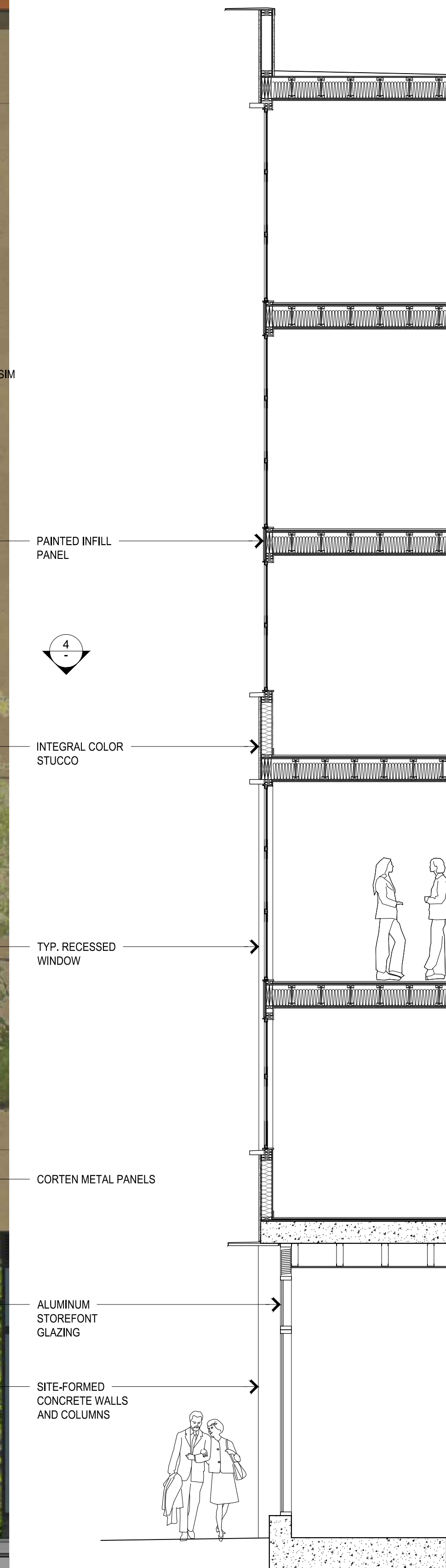

1 SECTION
1/8"=1'-0" @ 11X17 1/4"=1'-0" @ 24X36



1201
SAN PABLO
MIXED-USE

Berkeley, CA 94706

03.11.2021 SB-330 PRE-APPLICATION

04.29.2021 ZONING APPLICATION

07.13.2021 ZONING COMPLETENESS

ALL DRAWINGS AND WRITTEN MATERIAL APPEARING
HEREIN CONSTITUTE ORIGINAL AND UNPUBLISHED
WORK OF THE ARCHITECT AND MAY NOT BE
DUPLICATED, USED OR DISCLOSED WITHOUT WRITTEN
CONSENT OF TRACHTENBERG ARCHITECTS.

JOB: 1928

SHEET:

PRELIMINARY
STORMWATER
MANAGEMENT
PLAN

SW-1

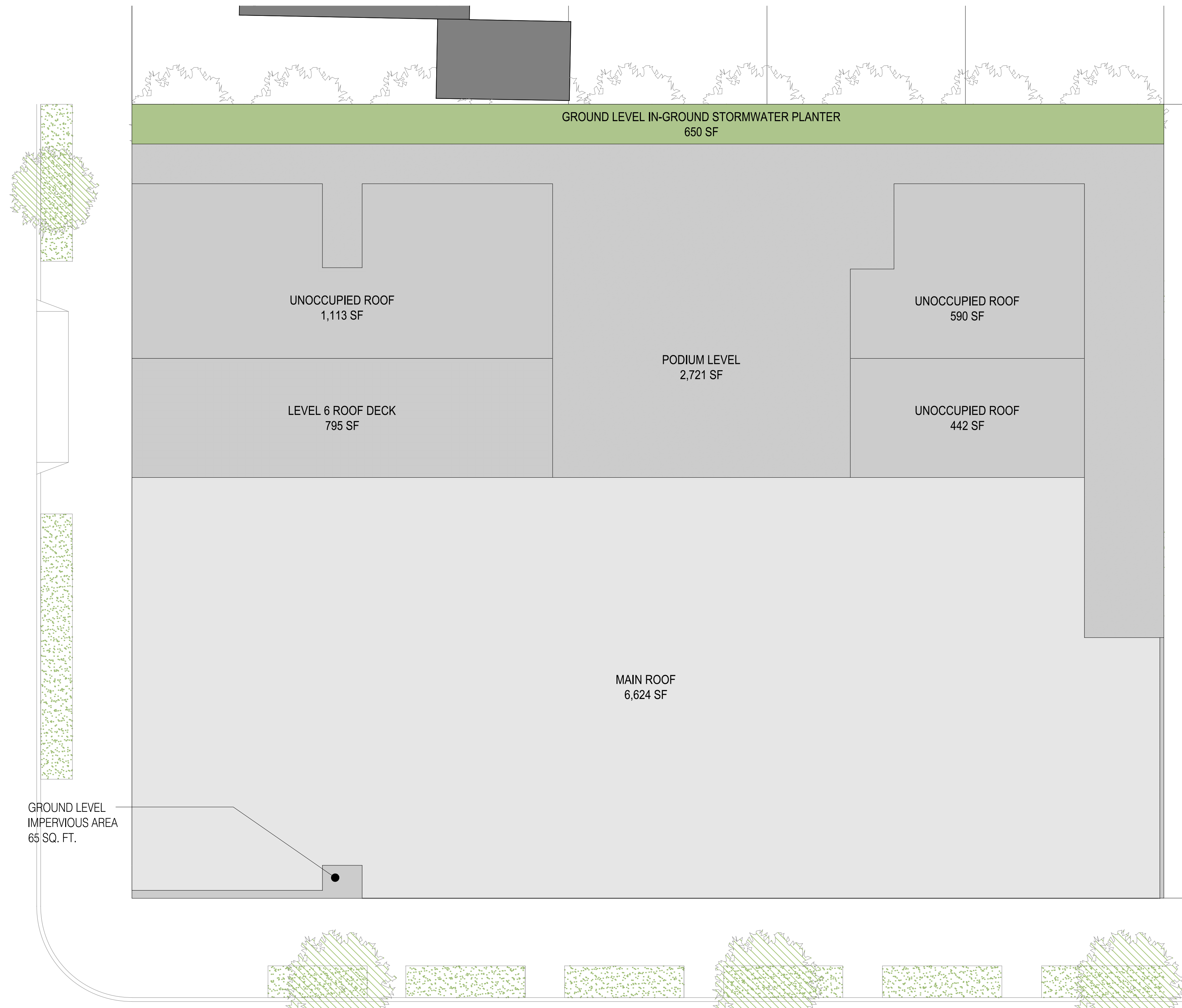

2 PRELIMINARY STORMWATER MANAGEMENT PLAN
1/16"=1'-0" @ 11x17 1/8"=1'-0" @ 24x36
0 4 8 16

STORMWATER CALCULATIONS

C3 APPLICABILITY									
TOTAL SITE AREA	13,000								
C3 THRESHOLD	10,000								
C3 REGULATED PROJECT	YES								
REQUIRED FLOW-THROUGH PLANTERS									
LOCATION	GROSS SF	SELF-TREATING AREA	TREATMENT AREA	%	TOTAL TREATMENT AREA	TOTAL PROVIDED PLANTER AREA	PERVIOUS PAVING	FILTER VAULT	
MAIN ROOF	6624	0	6624	4%	265				
LEVEL 6 ROOF DECK	795	329	466	4%	19				
UNOCCUPIED ROOF DECK	2145	0	2145	4%	86				
PODIUM	2721	1072	1649	4%	66				
GROUND LEVEL	715	650	65	4%	3	650			
TOTAL	13000	2051	10949		438	650			

PROVIDED TREATMENT PLANTERS

LEVEL	PLANTER	PLANTER AREA	
GROUND LEVEL IN-GROUND PLANTER	P1	650	
TOTAL PLANTER AREA		650	

SPECIAL PROJECTS (Appendix K)

CRITERIA FOR CATEGORY C (TRANSIT ORIENTED DEVELOPMENT) SPECIAL PROJECTS	Yes
1. Be characterized as a non auto-related land use project. That is, Category C specifically excludes any Regulated Project that is a stand-alone surface parking lot; car dealership; auto and truck rental facility with onsite surface storage; fast-food restaurant, bank or pharmacy with drive-through lanes; gas station, car wash, auto repair and service facility; or other auto-related project unrelated to the concept of Transit-Oriented Development.	Yes
2. If a commercial, achieve at least an FAR of 2:1.	N/A
3. If a residential development project, achieve at least a density of 25 DU/Ac.	N/A
4. If a mixed use development project, achieve at least an FAR of 2:1 or a gross density of 25 DU/Ac.	Yes

LOCATION CREDITS

% of the C.3.d Amount of Runoff that MayReceive Non-LID	Project Site Location	QUALIFIES
50%	50% or more of the site is located within a ¼ mile radius of an existing or planned transit hub	N/A
25%	50% or more of the site is located within a ½ mile radius of an existing or planned transit hub	N/A
25%	100% of the site is located within a PDA	N/A

DENSITY CREDITS

% of the C.3.d Amount of Runoff that MayReceive Non-LID	Land Use Type	Density Required to Obtain the Density Credit	PROPOSED	QUALIFIES
10%	Commercial	2 FAR		N/A
10%	Residential or Mixed Use	30 DU/Acre	220	YES
20%	Commercial	4 FAR		N/A
20%	Residential or Mixed Use	60 DU/Acre	220	YES
30%	Commercial	6:1 FAR		N/A
30%	Residential or Mixed Use	100 DU/Acre	220	YES

MINIMIZED SURFACE PARKING CREDITS

To qualify for any Minimized Surface Parking Credits, a Category C Special Project must first qualify for one of the Location Credits listed in Provision C.3.e.ii.(5)(c) above. (i) A Category C Special				YES
% of the C.3.d Amount of Runoff that MayReceive Non-LID	Percentage of the Total Post-Project Impervious Surface Dedicated to At-Grade, Surface Parking	PROPOSED	QUALIFIES	
10%	10% or less	0	YES	
20%	0% (except for emergency vehicle access, ADA accessibility and passenger and freight loading zones)	0	YES	

TOTAL CREDITS

LOCATION CREDITS	0%
DENSITY CREDITS	30%
MINIMIZED SURFACE PARKING CREDITS	20%

1 STORMWATER MANAGEMENT DATA

2421 Fourth Street
Berkeley, California 94710
510.649.1414
www.TrachtenbergArch.com



**1201
SAN PABLO
MIXED-USE**

Berkeley, CA 94706

- 03.11.2021 SB-330 PRE-APPLICATION
- 04.29.2021 ZONING APPLICATION
- 07.13.2021 ZONING COMPLETENESS

ALL DRAWINGS AND WRITTEN MATERIAL APPEARING HEREIN CONSTITUTE ORIGINAL AND UNPUBLISHED WORK OF THE ARCHITECT AND MAY NOT BE DUPLICATED, USED OR DISCLOSED WITHOUT WRITTEN CONSENT OF TRACHTENBERG ARCHITECTS.

JOB: 1928

SHEET:

CONCEPTUAL
GRADING PLAN

G-01

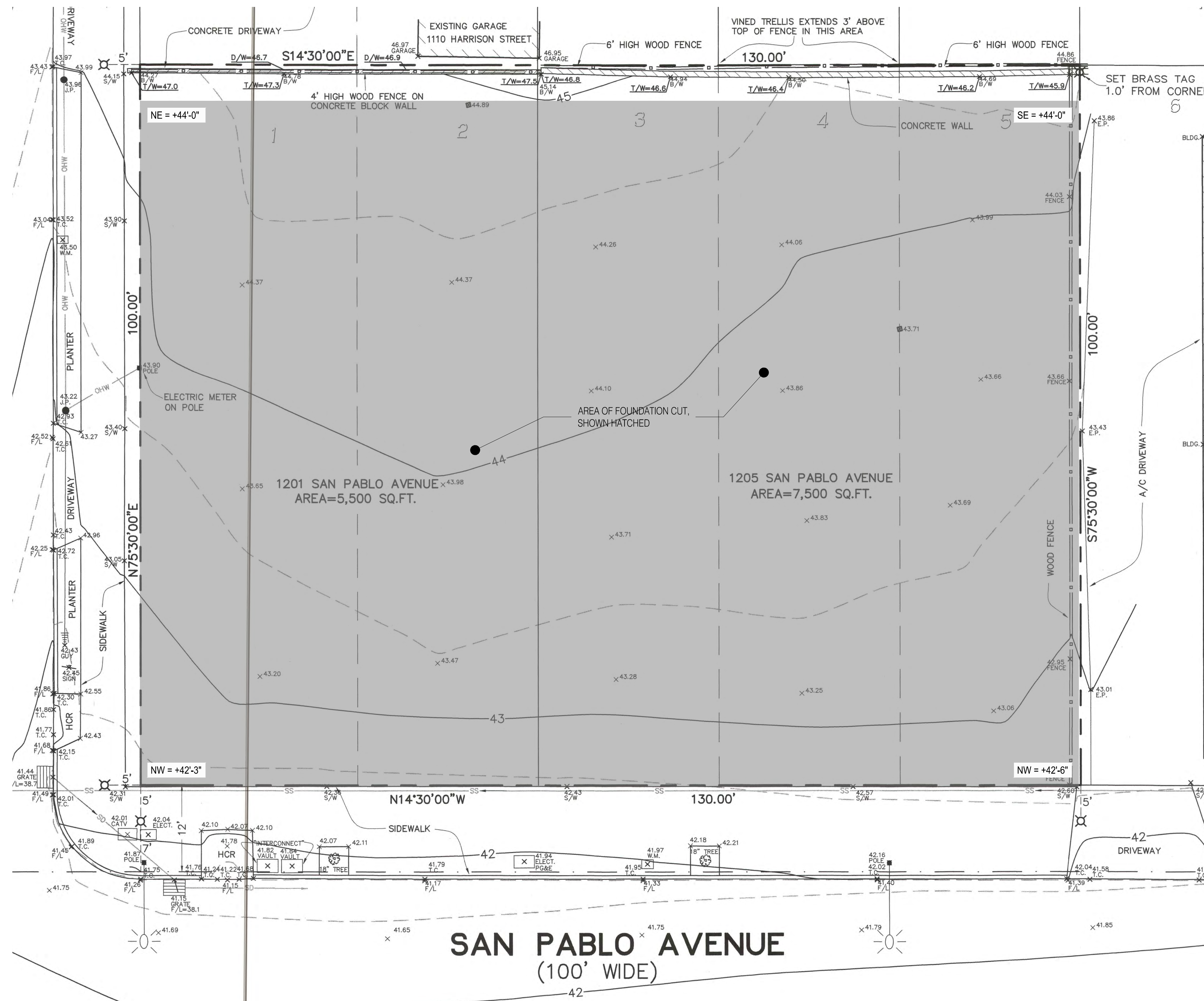

ESTIMATED QUANTITIES AND LOCATIONS OF FOUNDATION CUTS

	FEET	YARDS	
TOTAL CUBIC YARDS OF CUT		1115 (CUBIC YARDS)	
TOTAL AREA OF CUT	12346	1372 (SQUARE YARDS)	
AVERAGE DEPTH OF CUT	EXISTING ELEVATION (FT)	FINAL ELEVATION (FT)	
CORNER 1 - NW	42.25	40.75	1.5 0.5 (YARDS)
CORNER 2 - NE	44	40.75	3.25 1.083333 (YARDS)
CORNER 3 - SE	44	40.75	3.25 1.08 (YARDS)
CORNER 4 - SW	42.5	40.75	1.75 0.583333 (YARDS)

2 ESTIMATED CUT/FILL DATA

1 CONCEPTUAL GRADING PLAN

1/16" = 1'-0" @ 11X17 1/8" = 1'-0" @ 24X36



**1201
SAN PABLO
MIXED-USE**

Berkeley, CA 94706

- 03.11.2021 SB-330 PRE-APPLICATION
- 04.29.2021 ZONING APPLICATION
- 07.13.2021 ZONING COMPLETENESS

ALL DRAWINGS AND WRITTEN MATERIAL APPEARING
HEREIN CONSTITUTE ORIGINAL AND UNPUBLISHED
WORK OF THE ARCHITECT AND MAY NOT BE
DUPLICATED, USED OR DISCLOSED WITHOUT WRITTEN
CONSENT OF TRACHTENBERG ARCHITECTS.

JOB: 1928

SHEET:

MATERIAL
BOARD

MAT



INTEGRAL COLOR STUCCO
W/ SMOOTH TROWEL FINISH



METAL INFILL PANEL

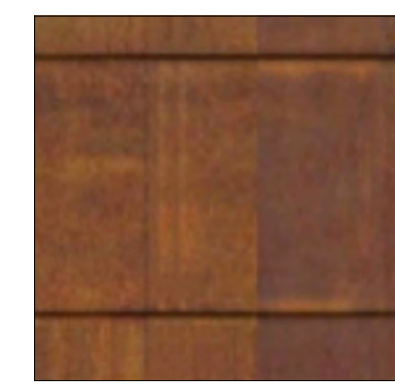

CORTEN METAL
PANEL



CORTEN METAL PANELS

INTEGRAL COLOR
STUCCO W/ SMOOTH
TROWEL FINISH

ALUMINUM
STOREFRONT

METAL INFILL
PANEL

CAST-IN-PLACE
CONCRETE

STEEL EAVE, PTD.

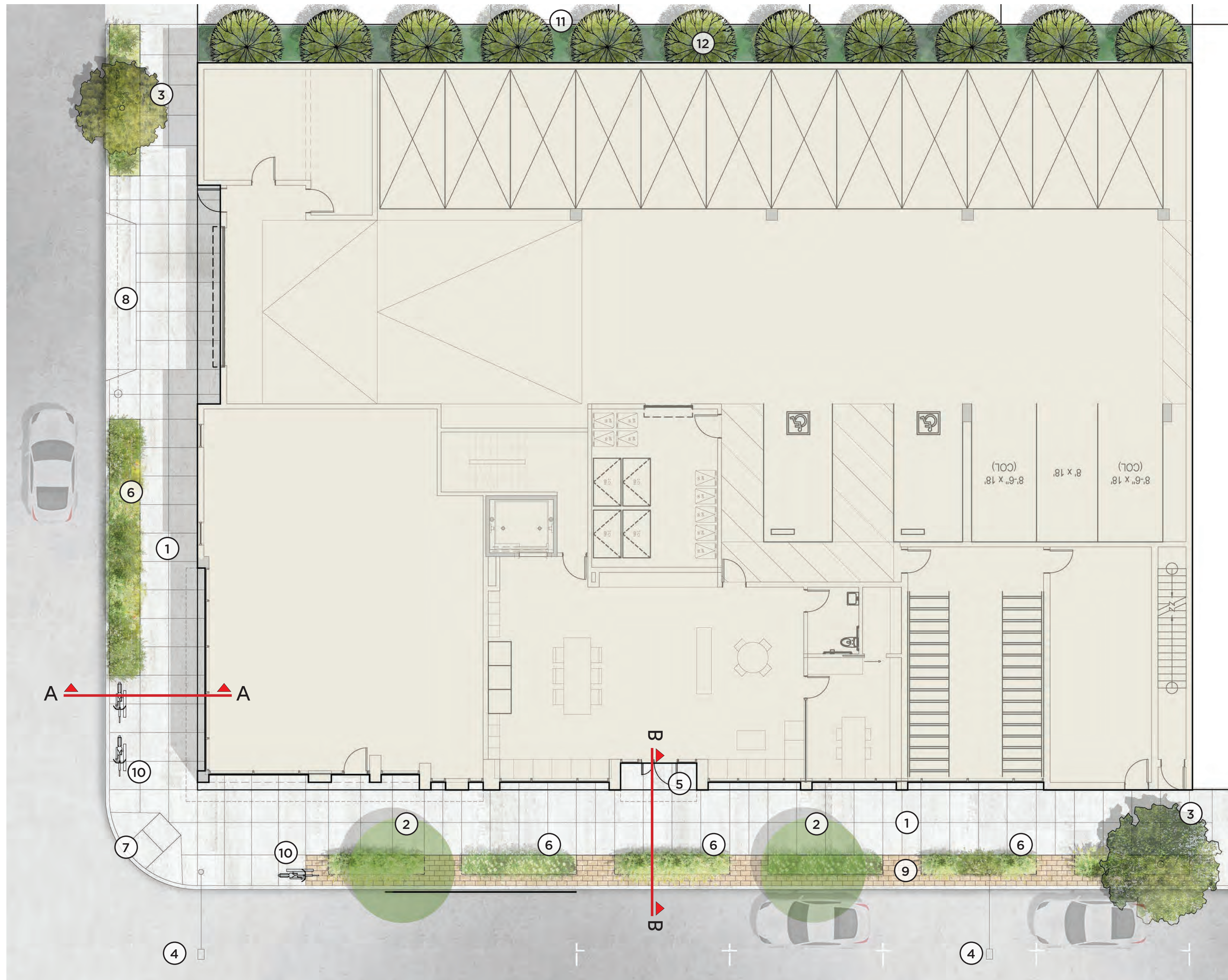

LEGEND

1. CONCRETE SIDEWALK PAVING
2. EXISTING STREET TREE, SEE SPECIFICATION
3. NEW STREET TREE
4. EXISTING STREET LIGHT
5. ENTRY TO LOBBY
6. AT-GRADE PLANTING
7. CURB RAMP
8. DRIVEWAY TO GARAGE
9. ENHANCED PAVING
10. NEW BIKE RACKS TYP. OF (3)
11. WOOD FENCE
12. LANDSCAPE MAINTENANCE AREA

TRACHTENBERG
ARCHITECTS

2421 Fourth Street
Berkeley, California 94710
510.649.1414
www.TrachtenbergArch.com

MILLER COMPANY
landscape architects

1585 FOLSOM ST. SAN FRANCISCO, CA 94103
415.252.7288 www.millercomp.com

1201 SAN PABLO MIXED-USE

Berkeley, CA 94706

07.13.2021 ZONING COMPLETENESS

PLANTING NOTES

1. PLANT SPECIES SELECTED FOR DROUGHT TOLERANCE, ECOLOGICAL BENEFIT AND SITE SUITABILITY IN TERMS OF SIZE, SHADE/SUN-TOLERANCE, AND MAINTENANCE NEEDS. PLANT MATERIAL FROM VARIOUS CALIFORNIA HABITATS HAS BEEN EMPHASIZED.
2. BAY-FRIENDLY BEST PRACTICES REGARDING MULCHING AND SOIL HEALTH WILL BE IMPLEMENTED TO FACILITATE PLANT GROWTH, INCLUDING SPECIFICATION OF ORGANIC SOIL AMENDMENTS AND COMPOST.
3. THE PLANTING DESIGN WILL GROUP PLANTS WITH SIMILAR EVAPOTRANSPIRATION FACTORS WITHIN LEGIBLE ZONES. EVAPOTRANSPIRATION WILL BE ASSIGNED PER WUCOLS VERSION IV.
4. THE LANDSCAPE ARCHITECT WILL PROVIDE PLANT AND SOIL MAINTENANCE RECOMMENDATIONS AS PART OF THE PROJECT SPECIFICATIONS.
5. LAWN AND TURF AREAS WILL NOT BE INCLUDED IN THE PROJECT.

IRRIGATION NOTES

1. THE IRRIGATION SYSTEM WILL BE DESIGNED BY A LICENSED IRRIGATION PROFESSIONAL.
2. A DEDICATED EBMUD METER OR SUBMETER WILL BE PROVIDED FOR THE IRRIGATION SYSTEM DESIGN WITH LOCATION AND POINT OF CONNECTION NOTED.
3. A MANUAL SHUTOFF VALVE, REDUCED PRESSURE BACKFLOW PREVENTER AND FLOW SENSOR WITH MASTER SHUT OFF VALVE WILL BE PROVIDED AFTER THE POINT OF CONNECTION.
4. WATER PRESSURE AND FLOW RATES AT POINT OF CONNECTION AND ALL REMOTE CONTROL VALVES WILL BE INDICATED ON IRRIGATION PLANS.
5. IRRIGATION PLANS WILL SHOW SCHEMATIC LOCATION FOR ALL MAINLINES, LATERALS, SLEEVES AND REMOTE CONTROL VALVES.
6. REMOTE CONTROL VALVES WILL BE OPERATED BY A SMART, WEATHER-BASED IRRIGATION CONTROLLER WITH RAIN SENSOR MOUNTED IN AN APPROPRIATE LOCATION.
7. ALL PLANTED AREAS WILL BE WATERED USING HIGH-EFFICIENCY IRRIGATION TECHNOLOGY, SUCH AS DRIP LINES AND BUBBLERS WITH FLUSH AND AIR RELIEF VALVES WHERE REQUIRED. ALL COMPONENTS SHALL HAVE FIXED FLOW RATES.
8. IRRIGATION ZONES WILL BE GROUPED BY WATER DEMAND AND THE OVERALL PLANTING PLAN WILL COMPLY WITH WATER USE LIMITATIONS OUTLINED IN THE LATEST WATER EFFICIENT LANDSCAPE ORDINANCE.



BIKE RACK

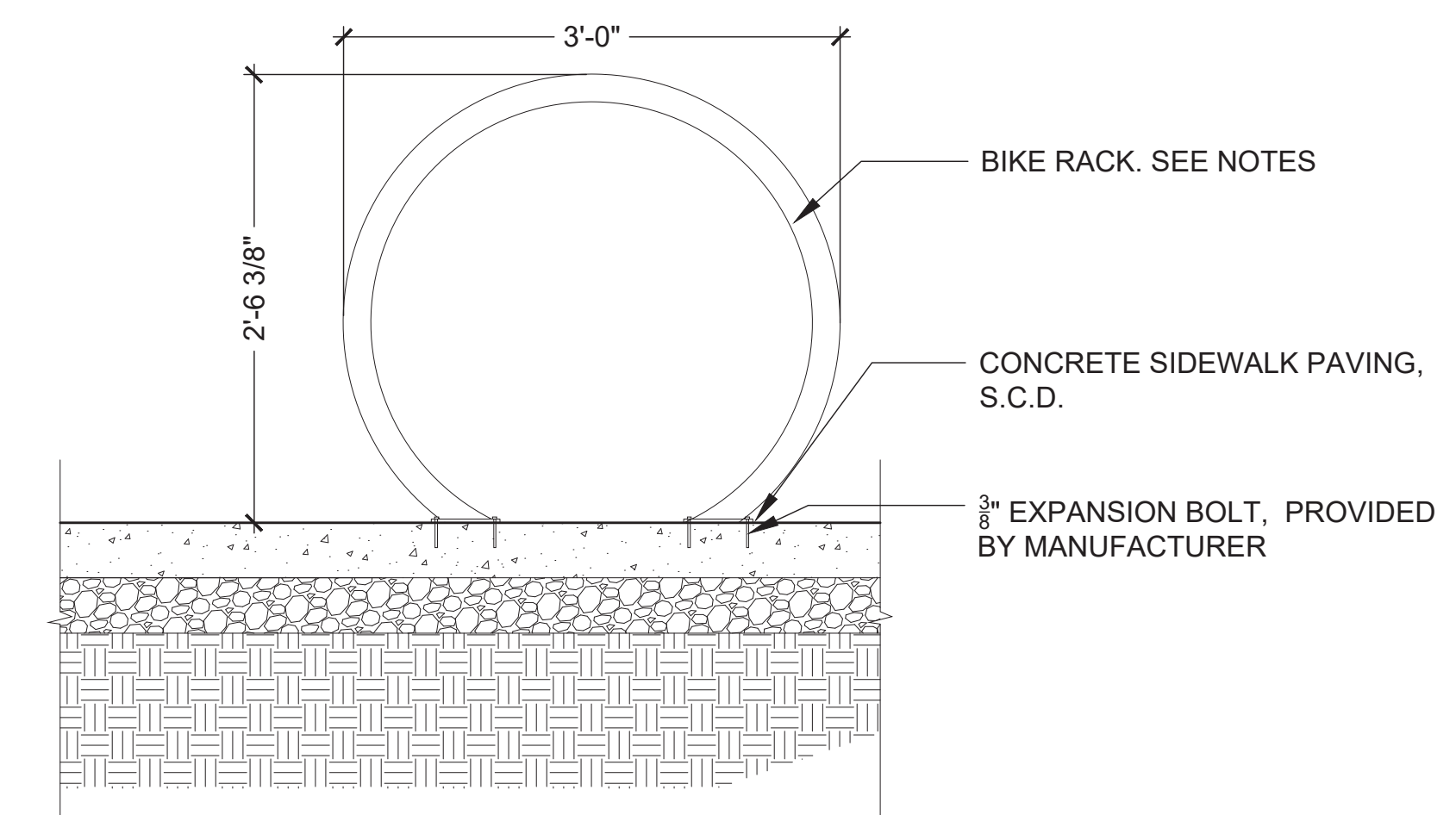

BIKE RACK: 'WELLE' CIRCULAR, SQUARE TUBE, HOT-DIPPED GALVANIZED FINISH, SURFACE MOUNT, MODEL: WCR02-SQ-SF-G.

BIKE RACK DETAIL

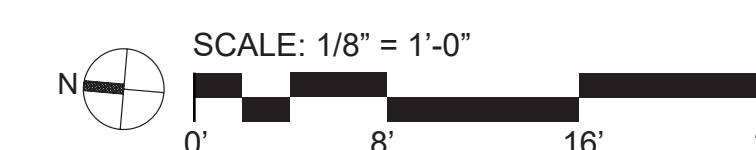

ALL DRAWINGS AND WRITTEN MATERIAL APPEARING HEREIN CONSTITUTE ORIGINAL AND UNPUBLISHED WORK OF THE ARCHITECT AND MAY NOT BE DUPLICATED, USED OR DISCLOSED WITHOUT WRITTEN CONSENT OF TRACHTENBERG ARCHITECTS.

JOB: 1928

SHEET:

LANDSCAPE PLANS GROUND LEVEL

L1.1

**1201
SAN PABLO
MIXED-USE**

Berkeley, CA 94706

07.13.2021 ZONING COMPLETENESS

ALL DRAWINGS AND WRITTEN MATERIAL APPEARING
HEREIN CONSTITUTE ORIGINAL AND UNPUBLISHED
WORK OF THE ARCHITECT AND MAY NOT BE
DUPLICATED, USED OR DISCLOSED WITHOUT WRITTEN
CONSENT OF TRACHTENBERG ARCHITECTS.

JOB: 1928

SHEET:

**LANDSCAPE PLAN
LEVEL 2**

L1.2

LEGEND

1. UNIT PAVERS
2. RAISED METAL PLANTERS
3. SPECIMEN TREES
4. INTENSIVE VEGETATED ROOF
5. MOVABLE CHAIRS WITH SIDE TABLES
6. DINING TABLES AND CHAIRS
7. LOUNGE CHAIRS AND TABLES
8. OUTDOOR KITCHEN COUNTER
9. OVERHEAD SHADE STRUCTURE
10. METAL PAVING EDGE
11. SCREEN
12. 42" PERFORATED METAL SCREEN
13. GRAVEL

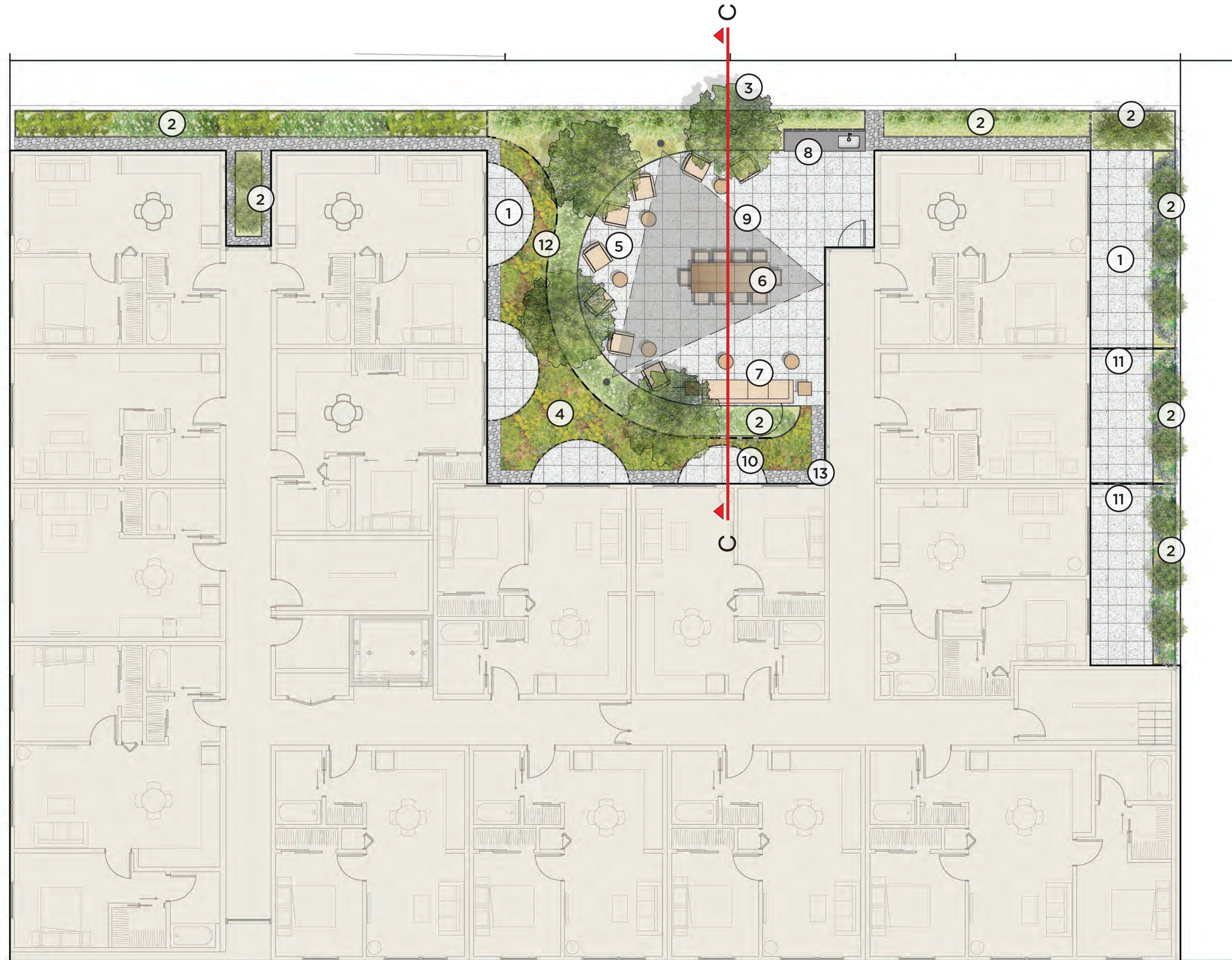

2ND LEVEL PLAN

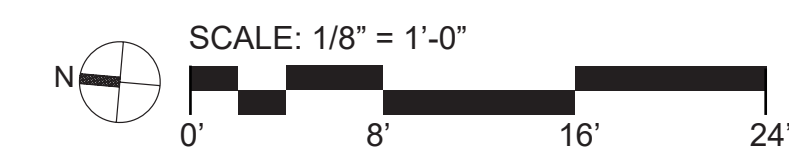

1201
SAN PABLO
MIXED-USE

Berkeley, CA 94706

07.13.2021 ZONING COMPLETENESS

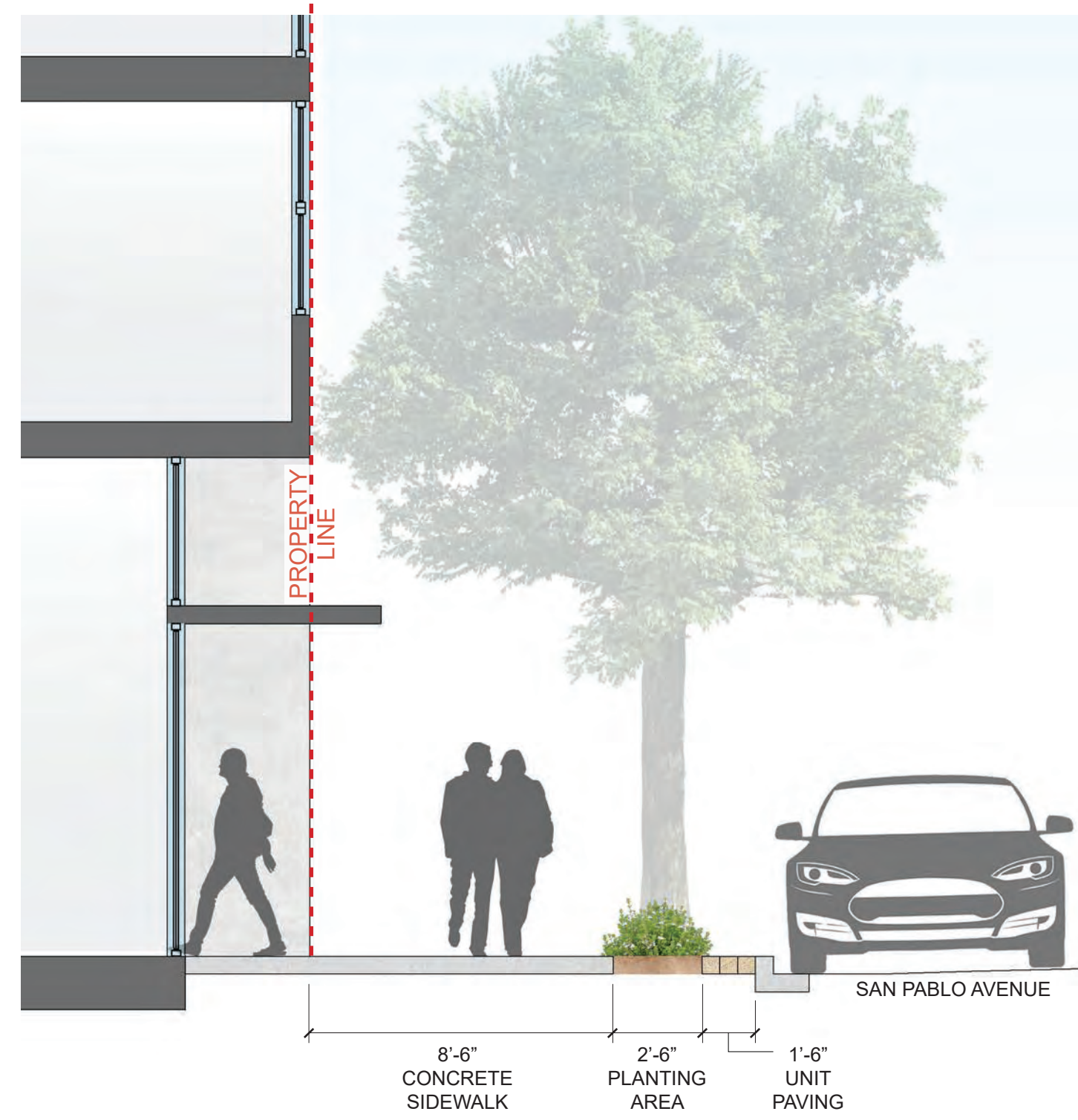

SECTION A-A: SAN PABLO AVE



SECTION B-B: HARRISON ST

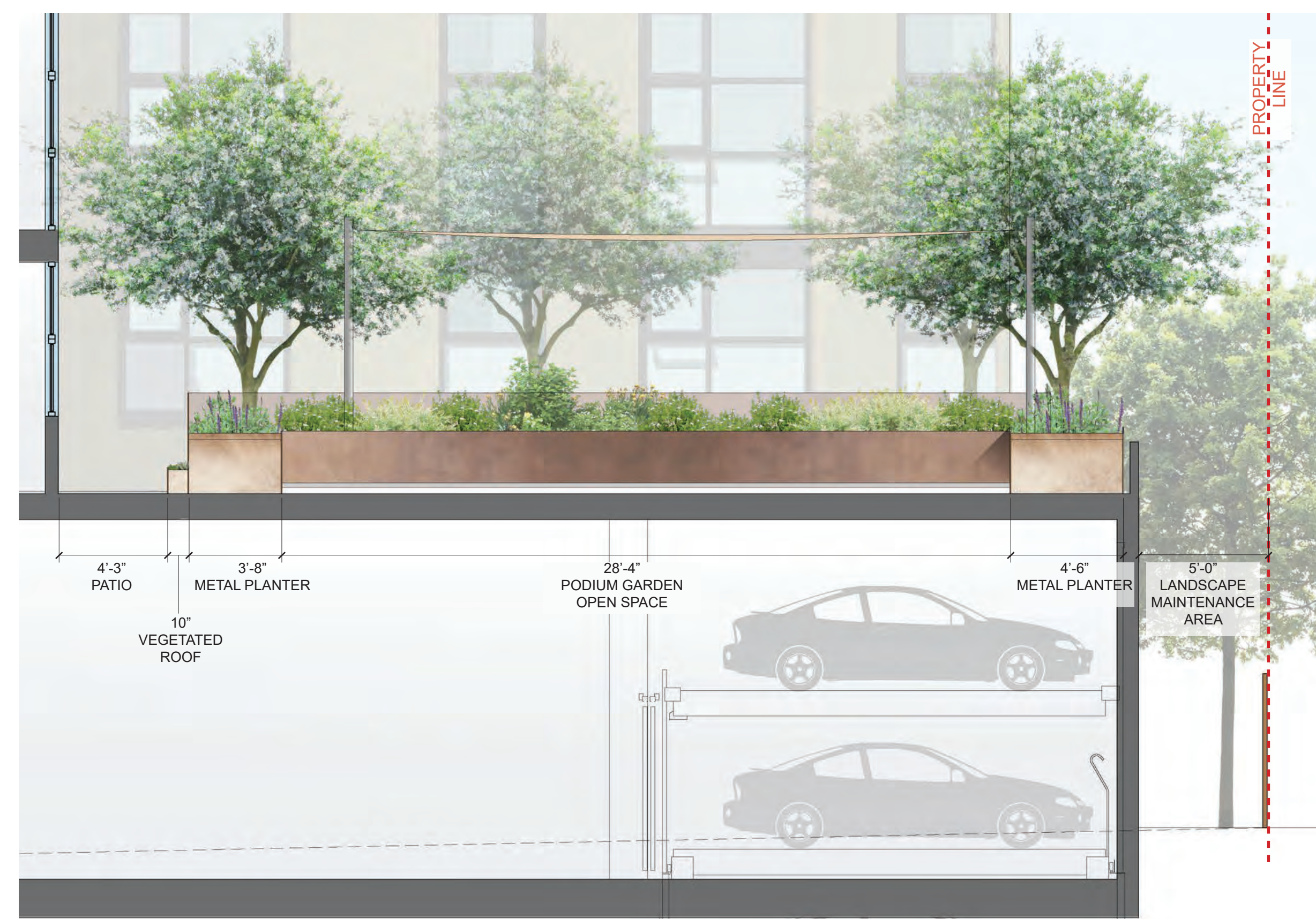

SECTION C-C: PODIUM GARDEN

OPEN SPACE TABLE				
	UNITS	RATIO	TOTAL	LANDSCAPE AREA
TOTAL UNITS	66	40	2,640	
TOTAL AREA PROVIDED			2,514	1,346
PODIUM LEVEL GARDEN			1,640	902
PODIUM LEVEL PATIOS			120	115
LEVEL 6 ROOF DECK			754	329

TOTAL LANDSCAPED AREA ON EACH LEVEL

STREET TREES



David Elm
Ulmus davidiana var.
japonica



Bronze Loquat
Eriobotrya deflexa

GROUND LEVEL PLANTERS



Box Leaf Azara
Azara microphylla



Creeping Fig
Ficus pumila



Stalked Bulbine
Bulbine frutescens



California Fuchsia
Epilobium canum



California Fescue
Festuca californica



Douglas Iris
Iris douglasiana

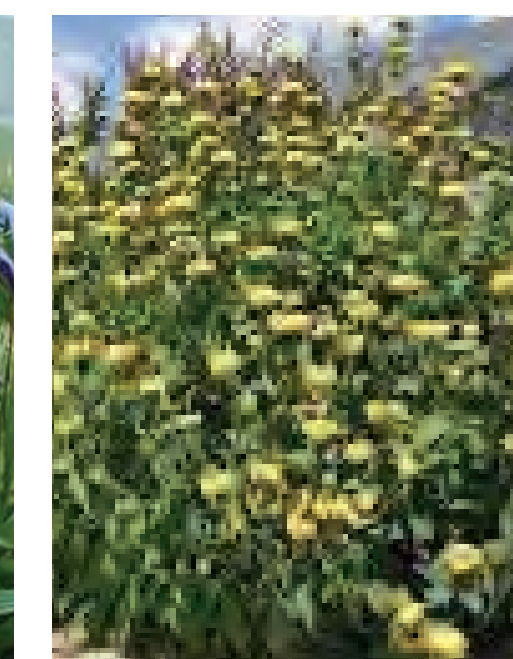

Jerusalem Sage
Phlomis fruticosa

2nd LEVEL



Evergreen Dogwood
Cornus capitata



Dwarf Mahonia
Mahonia aquifolium repens



Coffeeberry
Frangula californica 'Seaview'



Giant Wildrye
Elymus condensatus



Island Alum Root
Heuchera maxima



Western Swordfern
Polystichum munitum



Hummingbird Sage
Salvia spathacea

6th LEVEL TERRACE



Mimulus aurantiacus 'Pt. Molate'



Santa Barbara Daisy
Erigeron karvinskianus

PLANT PALETTE

ALL DRAWINGS AND WRITTEN MATERIAL APPEARING HEREIN CONSTITUTE ORIGINAL AND UNPUBLISHED WORK OF THE ARCHITECT AND MAY NOT BE DUPLICATED, USED OR DISCLOSED WITHOUT WRITTEN CONSENT OF TRACHTENBERG ARCHITECTS.

JOB: 1928

SHEET:

LANDSCAPE SECTIONS AND PLANT PALETTE

L1.4